

LT-20HP-WXT

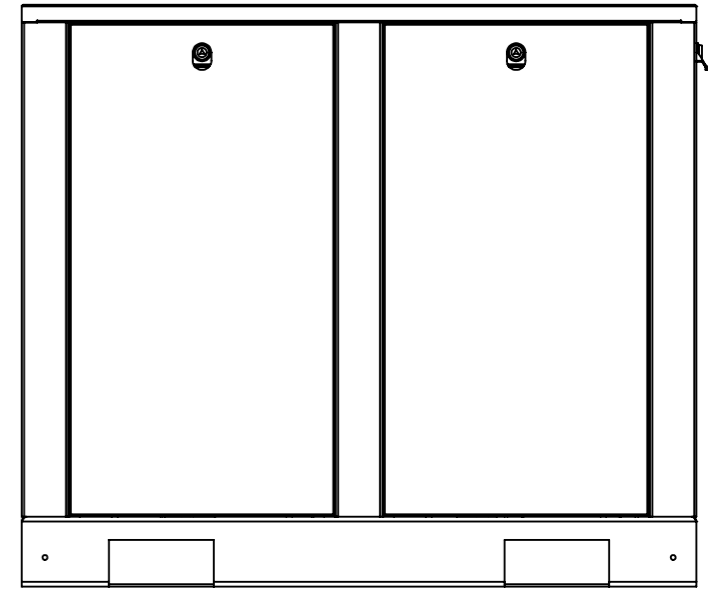

Ø 38 Alimentation

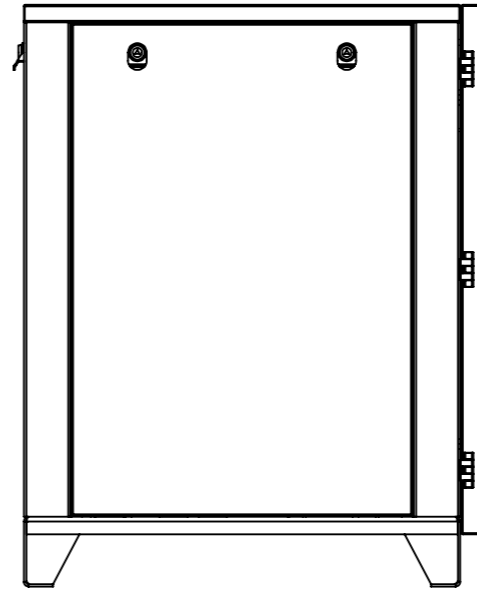
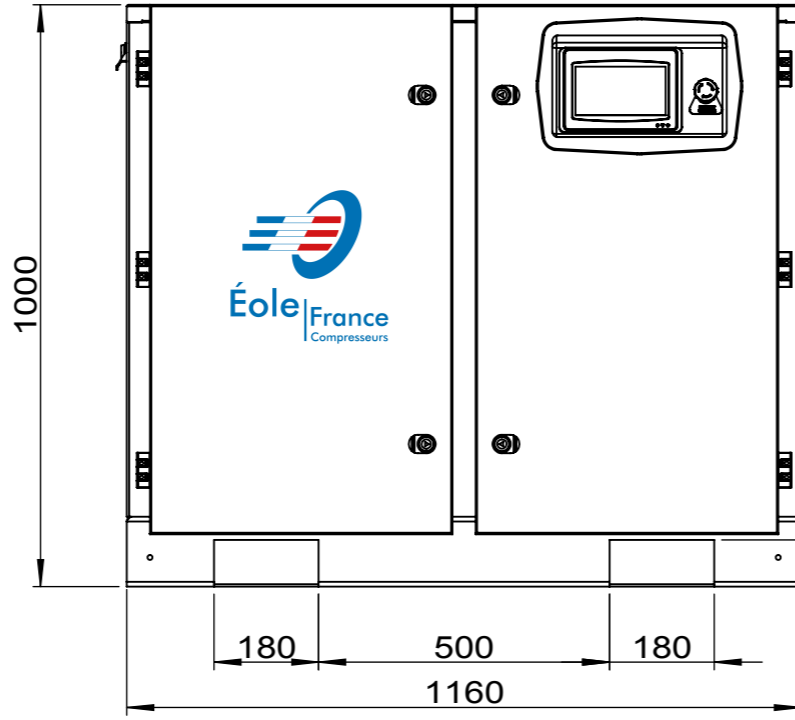
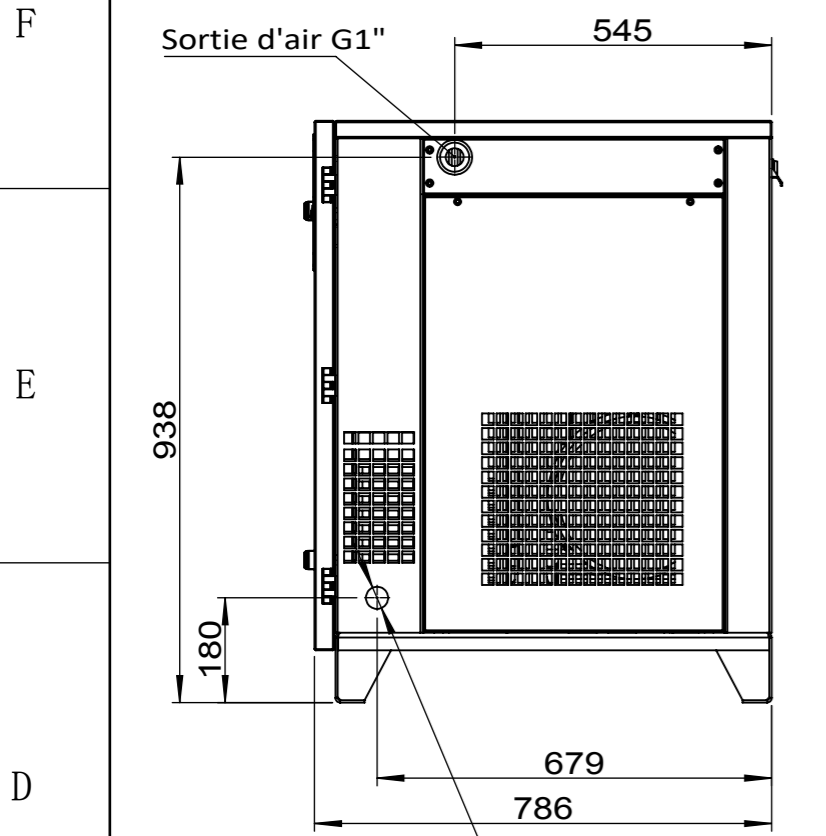
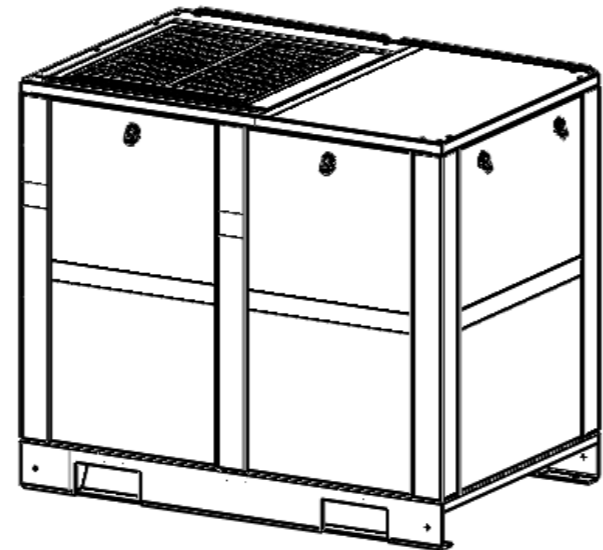
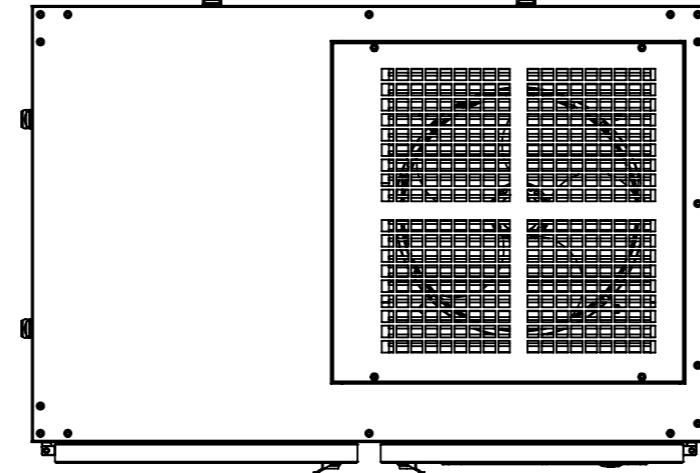
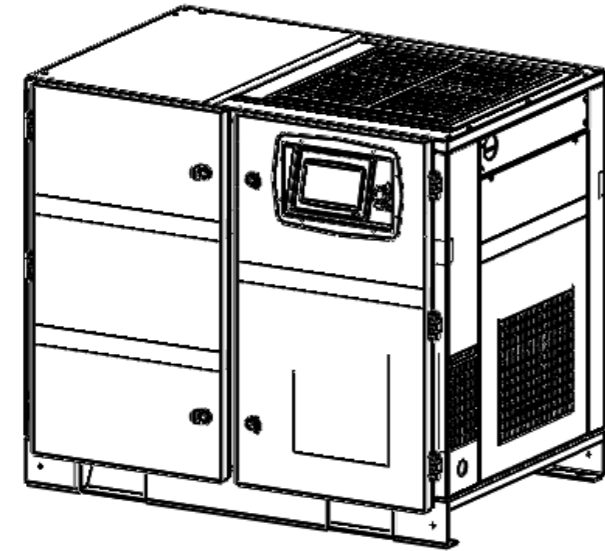

Débit volumique (m ³ /h)	54
Pression d'admission (bar)	1
Pression de refoulement nominale (bar)	15.95
Température d'air à l'admission (°C)	≤40°
Température de refoulement (°C)	≤ température ambiante + 15 °C
Mode de transmission	entraînement direct (accouplement)
Mode de contrôle	automate programmable (PLC)
Vitesse nominale du moteur (tr/min)	3500
Pression d'ouverture de la soupape de sécurité (bar)	17
Puissance nominale (kW)	11
Dimensions (L x l x H) (mm)	1160x786x1000



GAMME LAZ'AIR

LAZ 11

